

MOD. VBO 4 assi

RIBALTABILE POSTERIORE A VASCA
MODELLO VBO IN ACCIAIO ANTIUSURA HB 500
TRUCK 8X4 -20 MC

ROUND SHAPE REAR TIPPER BODY
MODEL VBO IN WEAR RESISTANT STEEL HB 500
TRUCK 8X4 -20 CM

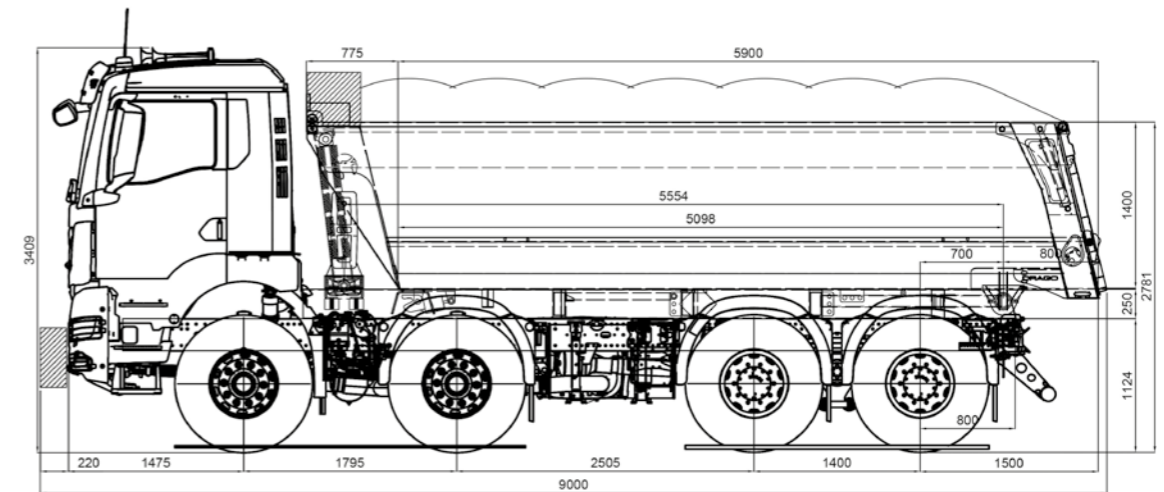

FORNITURA STANDARD

- Fondo in acciaio anti-usura HB 500 sp. 6 mm
- Sponde in acciaio anti-usura HB 500 sp. 4 mm
- Sponda posteriore basculante
- Profili laterali di protezione in INOX fiorettato
- Serbatoio olio, cassetta porta attrezzi, Parafanghi, Paracicli
- Telo di copertura elettrico in PVC
- Barra para-incastri rovesciabile manuale
- Verniciatura personalizzata con vs loghi aziendali

OPTIONAL

- Spessori maggiorati (a scelta, fino a 10/10 mm fondo/laterali)
- Scivolo per finitrice rimovibile
- Barra para-incastri pneumatica
- Sponda posteriore a sollevamento idraulico (asfalto/inerti o roccia)
- Sponda posteriore con scivolo idraulico per massi
- Sponda posteriore con apertura a libro/bandiera
- Nebulizzatore gasolio
- Coibentazione completa e certificata (DIN70001)
- Impianto intercambiabile abbinato
- Personalizzazione volumi e impiantistica
- Faretti extra, tanica acqua INOX, Telecamere
- Etc...

STANDARD SUPPLY

- Drago bolted tipping body in kit form complete of bolt and assembly guide
- Body floor in wear resistant steel HB 500
- Sideboards in wear resistant steel HB 500
- Frontboard in wear resistant steel HB 500 with roof cab-protection, compartment for tarpaulin cover and holder for tipping cylinder
- Tailgate in wear resistant steel HB 500 with automatic unhooking device
- Lateral protections

OPTIONAL

- Frontal telescopic cylinder (+200 kg)
- Sub-frame (+ 700 kg)
- Covering system (+ 90 kg)
- Rear extension for asphalt
- Lateral protections in stainless steel
- Tailgate with hydraulic opening
- 2 way folding tailgate
- Painting